

# stainless steel **grease traps**

## grease removal at-source

The GTS range of internal grease traps are manufactured using high grade stainless steel and are available in a variety of sizes to suit all applications.

Each GTS system contains an internal chamber with a baffle-wall which only allows effluent to discharge underneath it. This causes free-floating oil to remain in the chamber and allows grease-free effluent to pass on into the drainage system.

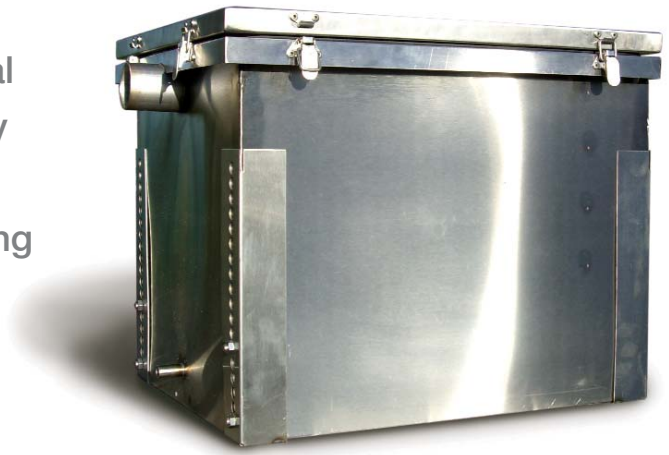

### Interception at source

Designed for 'at-source' removal the GTS systems are typically installed directly on the line requiring separation - be it sink, steaming-oven or dishwasher.

Installing at source enables the GTS systems to prevent internal build up of grease within pipe-work which can occur with externally located traps.

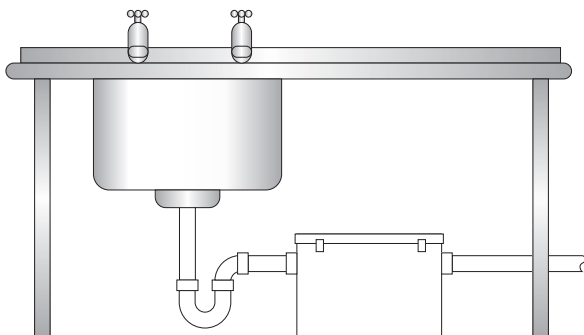

### Added features

**Integral Food Filter:** GTS units are fitted with a removable mesh basket which filters out food sediment.

**Odour control:** GTS units are fitted with a rubber seal and clip down lid to prevent odours escaping.

**Adjustable height:** GTS units are supplied with adjustable legs for easy installation.



# stainless steel **grease traps**

## grease removal at-source

### Sizing

To find out which GTS system is right for your application please contact Watling Hope.

Model	Application	Holding Capacity	Dimensions (w x d x h)	Inlet/Outlet Diameter	Weight
GTS05	domestic	5 litres	225mm x 150mm x 150mm	40mm	6kg
GTS20	single sink	20 litres	350mm x 300mm x 200mm	50mm	10kg
GTS40	single sink	40 litres	500mm x 400mm x 200mm	50mm	16kg
GTS60	single sink	60 litres	500mm x 400mm x 300mm	50mm	19kg
GTS80	single sink	80 litres	500mm x 400mm x 400mm	50mm	22kg
GTS60M	multi sink	60 litres	500mm x 400mm x 300mm	110mm	19kg
GTS80M	multi sink	80 litres	500mm x 400mm x 400mm	110mm	22kg
GTS120M	multi sink	120 litres	750mm x 400mm x 400mm	110mm	27kg
GTS160M	multi sink	160 litres	1000mm x 400mm x 400mm	110mm	33kg
GTS200M	multi sink	200 litres	1200mm x 400mm x 400mm	110mm	38kg

### Installation

The GTS stainless steel filtered grease traps come fully assembled and ready to fit by a qualified plumber.



If fitting into an existing system, check first that the drain pipes on the outlet side have been cleaned. Set the stainless steel brackets (supplied) to the required inlet/outlet height.

Connect to inlet and outlets using standard Multifit connectors (not supplied). The low level 15mm pipe must be connected to the main drain with a shut off valve (not supplied). This will aid the deep cleaning operation. Once fitted, return the warranty card supplied with the unit to activate customer support.

(Adjustable mounting brackets not available on the GTS05, GTS120M, GTS160M and GTS200M).

### Improve the performance of your grease trap with Biological Treatment

To reduce the need to empty and control odour Watling Hope recommend using the Grease Goblin biological treatment system. The Grease Goblin regularly injects a fluid formula of enzymes and bacteria into the trap.

The biological agents within the fluid work to degrade the accumulated grease and control odours.



BUY ONLINE  
[www.watlinghopedirect.co.uk](http://www.watlinghopedirect.co.uk)